

BOAT REFRIGERATION

Seminar

12/24 Volt Refrigeration

What works and what doesn't

By the author of books on boat refrigeration

R. L. Kollmann

<http://www.kollmann-marine.com>

Refrigeration Books

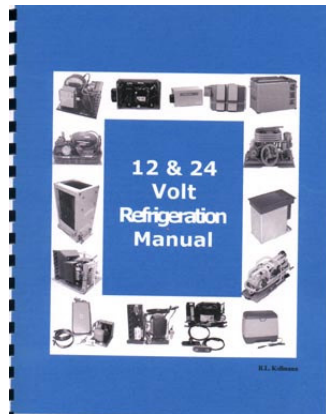

NEW 2003

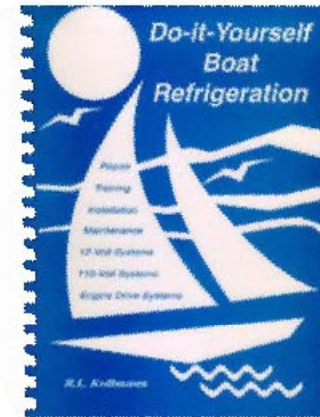

2000

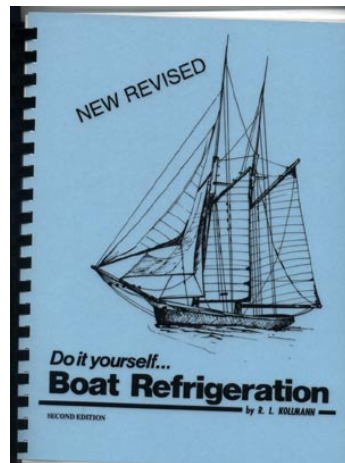

1995

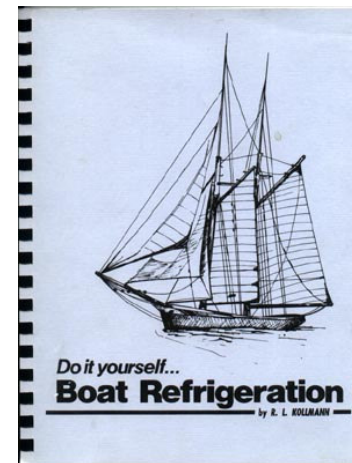

1984

Overview

- **How cold a refrigerated box do you want?**
- **How to determine the box's daily heat load**
- **Selecting the correct refrigeration system**
- **Troubleshooting**
- **Fine tuning for better performance**
- **DC power management**
- **Ice making onboard**

Products mentioned or pictured in this presentation are only examples and should not be considered as an endorsement of any one product.

Degree of Refrigeration

How Cold a Cooler ?

A cooler prevents spoilage for one day by maintaining a box temperature of 46° F.



Degree of Refrigeration

How cold a Refrigerator?

A refrigerator extends sensitive food's freshness one week at 34° F.



Degree of Refrigeration

How about a High temp. Freezer?

A 21°F. Freezer for short term frozen storage two to four weeks



Degree of Refrigeration

How about a Low Temp. Freezer?

A zero degree Freezer for long term storage



How Much cooling is required?

**There are four questions to be answered
to determine Total Box Heat Load**

- **Determine if the box is to be a Cooler, Refrigerator or a Freezer.**
- **Determine the worst case cruising area climate**
- **Estimate the amount and if possible the R value of insulation and the box size in cubic feet.**
- **Add any other heat load items such as, number of people on-board and special requirements.**

Selecting Refrigeration

Based on Climate and Seawater
Temperatures

United States

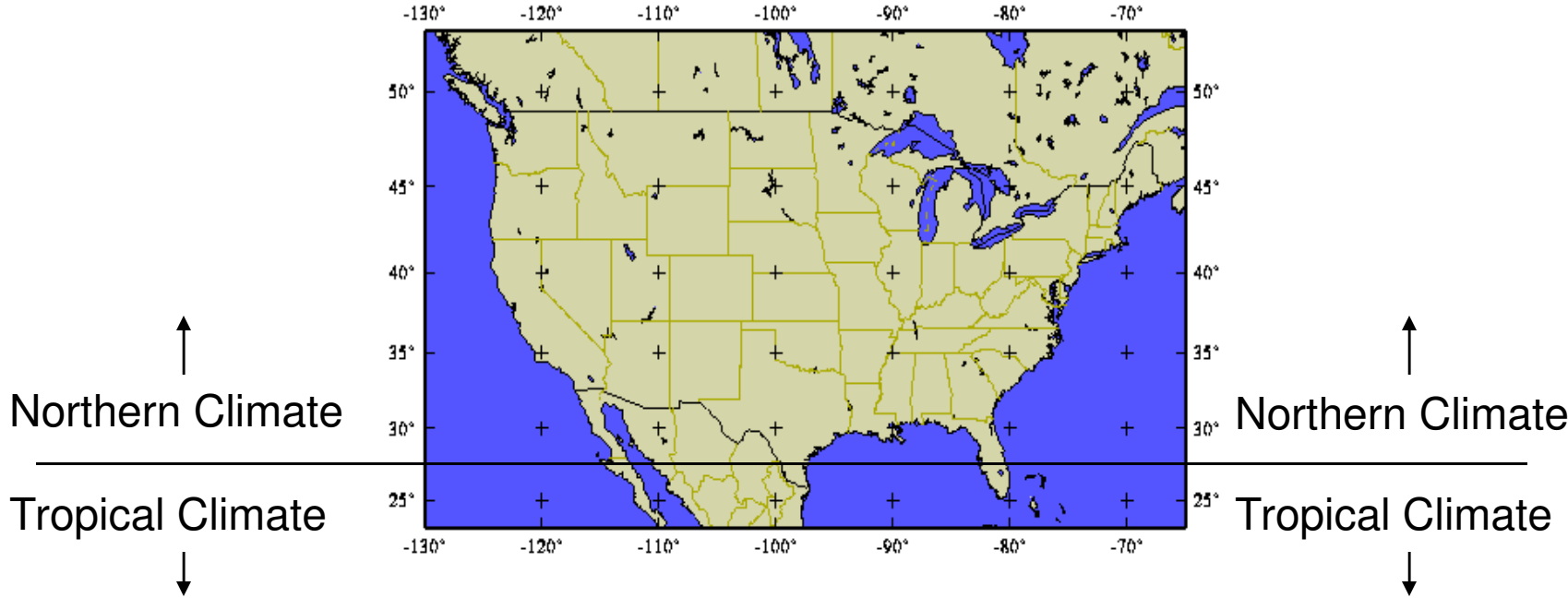

Seawater Effect

Wonder why refrigeration never seems to be as good as the manufacturers say?

One answer could be they fail to provide information on the effects of seawater temperature on a boats refrigeration system. Yes, even air cooled refrigeration is effected by the boat's hull temperature.

A system designed and installed in San Francisco developed serious problems when arriving in Cabo Mexico due to the difference in water temperatures.

- **Here is an example of seawater temperatures one day in August 2003 :**

Lowey Rocks FL. 86.7 Deg.

Santa Monica CL. 69 Deg.

San Francisco CA. 54.5 Deg.

- **25 degree increase in water temp. can double the daily power (Btu) requirement.**

Insulation How Much Is Enough

Rarely do production boats have enough insulation for freezers in the tropics. The combined thickness of insulation for a freezer in the tropics should be equal to an R value of 30.

The amount of insulation needed to reach this R value:

Extruded Polystyrene Foam	7.5 inches.
Polyurethane or Polyisocyanurate Foams	5.0 inches
Vacuum Insulated Panel (VIP) plus one or two inches of foam panels	1.0 inch

Production Boat Refrigerator Daily Heat Load Shortcut

You could try to compute the Btu of heat gain through every square inch of exterior insulated surface then add to that all other variables or use my shortcut method.

Lets start with worst case conditions three inches of insulation, 86 degree seawater, 90 degrees at midnight and a crew of two.

Use the following Btu figures for each cubic ft:

Refrigerator daily heat load 600 Btu per cu. ft.

Freezer daily heat load 1200 Btu per cu. ft.

Example to follow later

Variables To Be Added To The Shortcut Daily Heat Loads

**Daily food product through-put was built into the Shortcut
Figures based on the crew of two, each additional person will
add another 1000Btu per day.**

**The shortcut figures were based on a top loading box. Front
opening doors create a greater exposure to air infiltration.
For a front opening door add 15 Btu per each linear inch of door
seal.**

**One pound of ice per person per day is already built in, add
150 Btu for each additional pound per day.**

Example to follow later

Example Of A Four cu. ft. Refrigerator Operated In The Tropics

Four cu. ft. times 600 = 2400 Btu.
Two additional people on board = 2000 Btu.
Front opening door fourteen inch square
56 inches of seal X 15 Btu per in. = 840 Btu.

Total Btu of cooling required per day	<hr/>
	5240 Btu.

Daily Btu Requirement Will Determine Size of Refrigeration System

- The example's worst case in the tropics requires 5240 Btu of heat removal.
- These Btu figures can be reduced by 2% for each degree of decrease in seawater temperature.
- The same example box in California may only require $\frac{1}{2}$ the heat removal 2620 Btu.

Compressor Selection

- **Once the total daily heat load is known a compressor can be selected to power our refrigeration system**
- **All compressor output figures will be based on an evaporator temperature of +10 degrees F in order to make the selection.**
- **The compressor and other components need to be sized to exceed the daily worst case load. In the example of 5240 Btu a day for a month or two each year. A compressor with a daily capacity of 7500 Btu is adequate.**

Next a review of the available 12 volt Compressors.

Swing Compressors

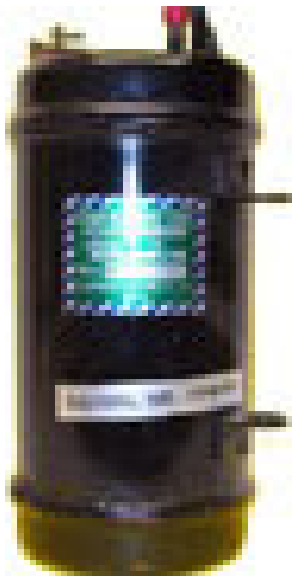

- **Swing bouncing electromagnet compressors are used in many small cabinet refrigerators Norcold and Engel and others.**
- **Norcold has two Ice box conversion units that use the swing compressor.**
- **Swing compressor's 24 hour output 5736 Btu is too small for this example it would need to run 24 hours per day.**

Danfoss BD35 and BD 50 Compressors



- Are both the same size externally but the BD 50 has 30% greater capacity with a +10 degree F. evaporator temperature
- The major advantage of these compressors is their speed and output is adjustable.

BD35-24 hour capacity 9408 Btu

BD50- 24 hour capacity 12528 Btu

Large Direct Drive and Belt Driven 12 Volt Refrigeration Units

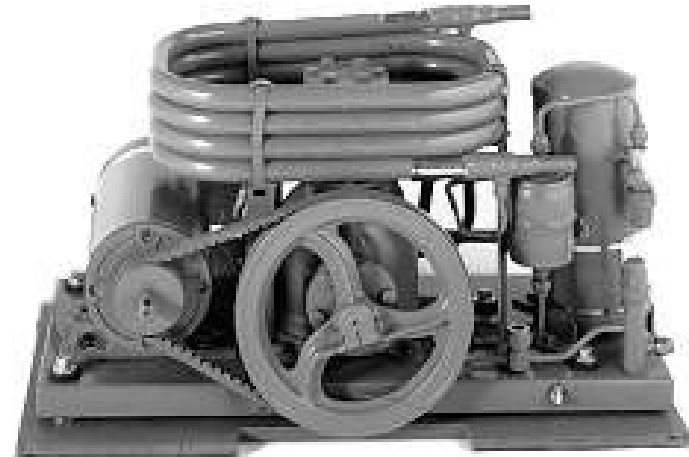

- Do to their size these units must be water cooled.
- These units are available from $\frac{1}{4}$ to 2 HP. With daily capacities from 24,000 to 72,000 Btu.

The smallest of these units is too large to efficiently cool the small example box.

The Danfoss BD 35 Compressor Is The Closest Match

- **The BD 35 has an adjustable speed range from 2000 rpm to a maximum of 3500 rpm.**
- **As the seasons and cruising area temperatures change the compressor's speed can be reset for the best energy efficiency.**
- **Whether in the tropics or the far north this compressor can handle our example four cu. ft. box.**

Other Refrigeration Component Selections

- Once a compressor is selected the other components of the system must be chosen to match the total daily Btu requirement.**
- Manufacturers of systems sell the compressor and condenser as a unit then provide a selection of recommended evaporators for each compressor/condensing unit.**
- If a compressor is intended to run at a slower speed as is the case with some systems the condenser may limit the size of the evaporator.**

Holding Plate Versus a Thin Plate Evaporator

Holding Plate Advantages:

- Energy can be stored in the holding plate instead of in the battery.
- Holding plates provide a flywheel effect when warm food product is put in the box.
- Holding plates are more efficient if the system incorporates an expansion valve and a receiver.

Holding plate disadvantages:

- Slow to respond and change temperature.
- Poor box temperature control.

Evaporators

- **Regardless of whether the evaporator is a holding plate or a thin plate it is the total exterior surface skin area of the evaporator that absorbs and disposes of the box's heat.**
- **An evaporator should be large enough to handle the output capacity of the compressor. Most manufacturers that sell 12 volt conversion systems recommend the correct size evaporator for their condensing unit.**
- **The BD35 compressor selected to cool the example box will be required to run at 3000 rpm in the tropics. We now need to find a manufacturer that can supply an evaporator with a condensing unit that is designed to match our needs.**

Seawater Cooled Refrigeration?

- **It is difficult to dispose of the amount of heat generated in a boat from refrigeration systems larger than 1/6 HP without water cooling.**
- **Experience has shown the water cooling of small systems compromises their reliability and is not recommended.**
- **To be more efficient water cooling requires moderate water temperatures otherwise the current draw of the water pump or cooler water off sets any efficiency gain over air cooling.**

Reliability of Small Water Cooled 12 Volt Pumps

- **There are two types of 12 volt pumps used to circulate water through these small refrigerator condenser's, Circulating and Positive Pressure. These pumps only have a service life of 7 to 12 months in the tropics.**
- **Circulating pumps are more prone to problems as any foreign particle can stop the magnetic rotor. Circulating pumps also can not pump air.**



Water Cooled Condenser Failures

- The life cycle of air cooled Danfoss condensing units runs from 15 to 20 years
- The life of a water cooled Danfoss system is questionable do to the frequent failures of the condensers.
- When a water condenser fails the entire system is scrap do to water entering the complete system

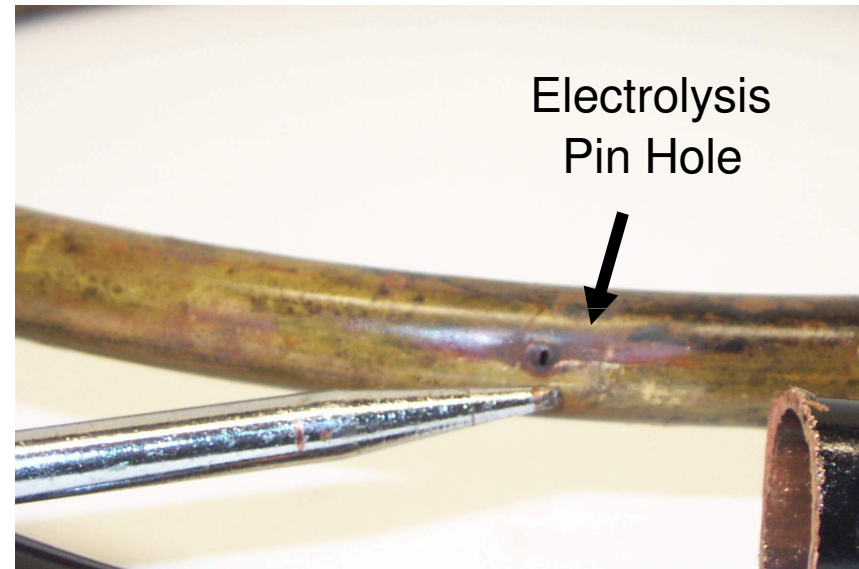

Purchasing the correct unit

The BD35 air-cooled condensing unit needs a large enough evaporator to handle this compressor output at 3000 rpm. It is desirable to have a small freezing section and daily ice production is needed. The compressor speed must be adjustable for at least seasonal changes.

Shopping For a System

- In order to meet daily ice needs there must be some sort of a freezing section. If the box is to have a divider spillover system a large holding plate in the freezer side could satisfy the objective. Another option is the Chamber (bin) evaporator.
- After reviewing ice box conversion units on the web and sale catalogs I found these matches for an example system; Technautics, Grunert, Electricboat and Nova Kool. Adler Barbour and Frigoboat do not have air cooled BD35 units. There may be others but these manufacturers are enough for our example.
- Selection of which manufacturers unit to purchase needs to be influenced by how the airflows across the condensing unit. The unit must draw air from one area and dispose of it in another area.

Alternative Using the Danfoss BD 50 Compressor

- **The BD50 compressor is a good match for our example 4 cu. ft. box in the tropics when operated at lower speeds, although it would be less efficient in cooler climates.**
- **Here are two of the very best BD50 Systems:**
 - Adler Barbour's Cold Machine with large chamber evaporator**
 - Frigoboat's Capri 50-SSC with model 350 large chamber evaporator**

In case these evaporators do not fit the shape of the box a smaller one is available. Both are also available in vertical and horizontal models.

Collecting Test Data

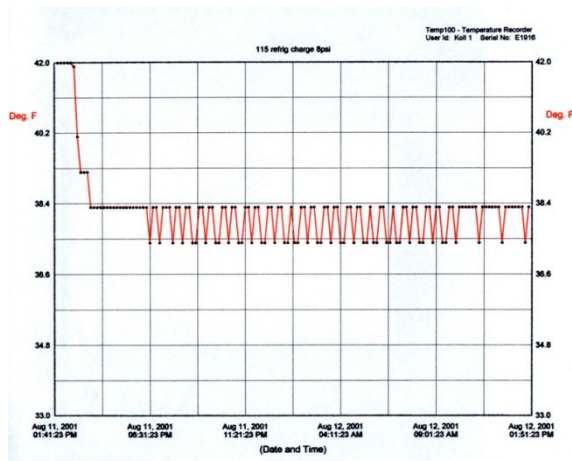
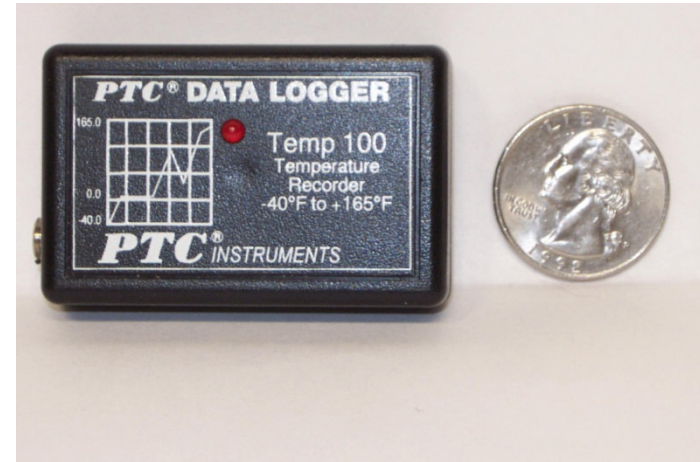
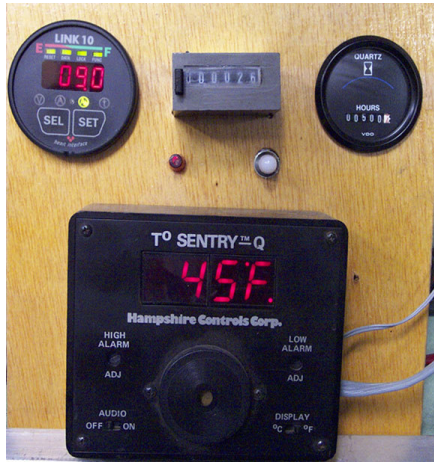

Adler Barbour for 24 hours

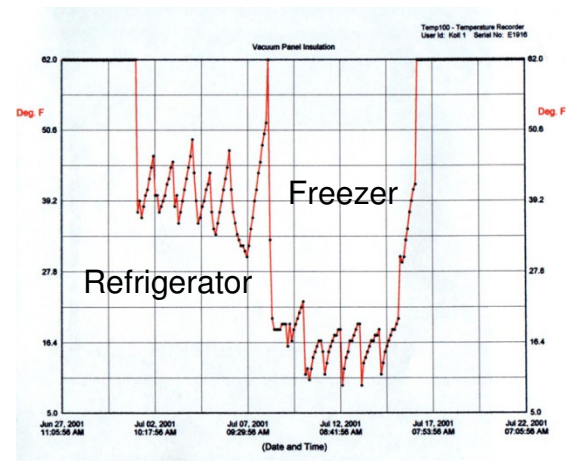

Holding Plates Two weeks

Performance Testing

- **I have tested over 30 different configurations of boat refrigeration before writing my 12/24 Volt Refrigeration Manual. By recording amp-hrs, start cycles, temperature and time every ten minutes a true efficiency profile is possible on each system tested.**
- **The new and old 12 volt compressors are only efficient if their output capacity matches the same capacity needs of the box they are cooling.**
- **The following chart demonstrates the effects of compressor size and speed on daily power consumption.**

Performance Comparison Of Danfoss Compressor Speeds

Compressor	Speed	24 Hour Amp-Hrs.
BD50	2000 rpm	41.5
BD50	2500 rpm	46.4
BD50	3000 rpm	52.6
BD50	3500 rpm	60.6
BD35	3500 rpm	49.2
BD35	2000 rpm	33.0
BD3	2500 Fixed	55.4

These tests were all conducted under the same conditions in a poorly insulated 3 cu. ft. box.

The lesson here is over capacity results in poor energy efficiency.

Compressor speed

Only applies to Danfoss BD35 and BD50 compressors

- **Many manufacturer's instructions don't mention the speed change feature.**
- **Why would you want to change speed?**
 - a. Changes in cruising area temperature.**
 - b. Guests on board.**
 - c. Restocking the box.**
 - d. The box needs more cooling capacity than originally anticipated.**
- ❖ **If the compressor speed is increased above what is preset by the manufacturer, increased air flow may be necessary over both the condenser and evaporator to improve their efficiency.**

Speed Resistor Locations

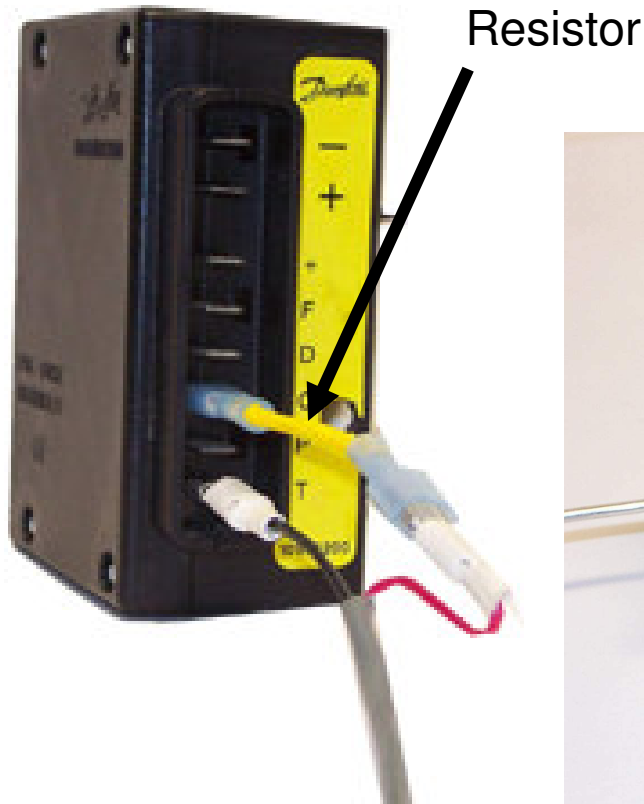

Electrical Module
Common location

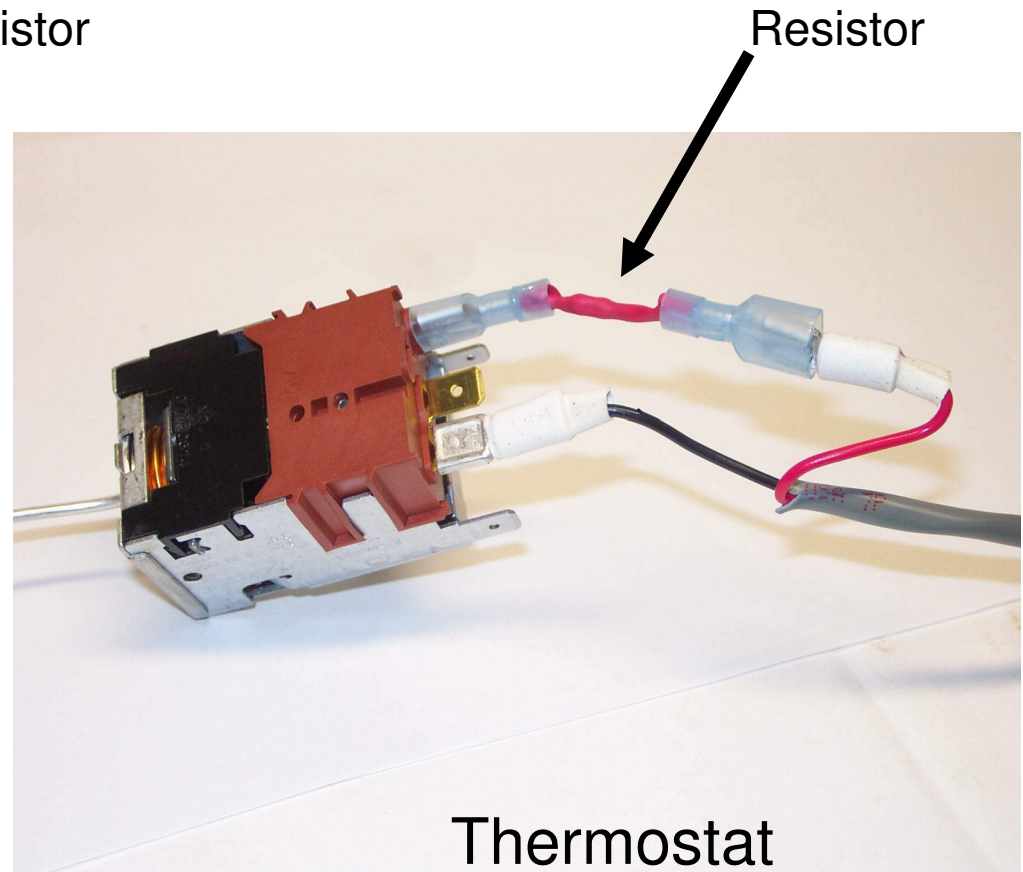

Thermostat
Adler Barbour location

Add Single Resistor to Change Speed

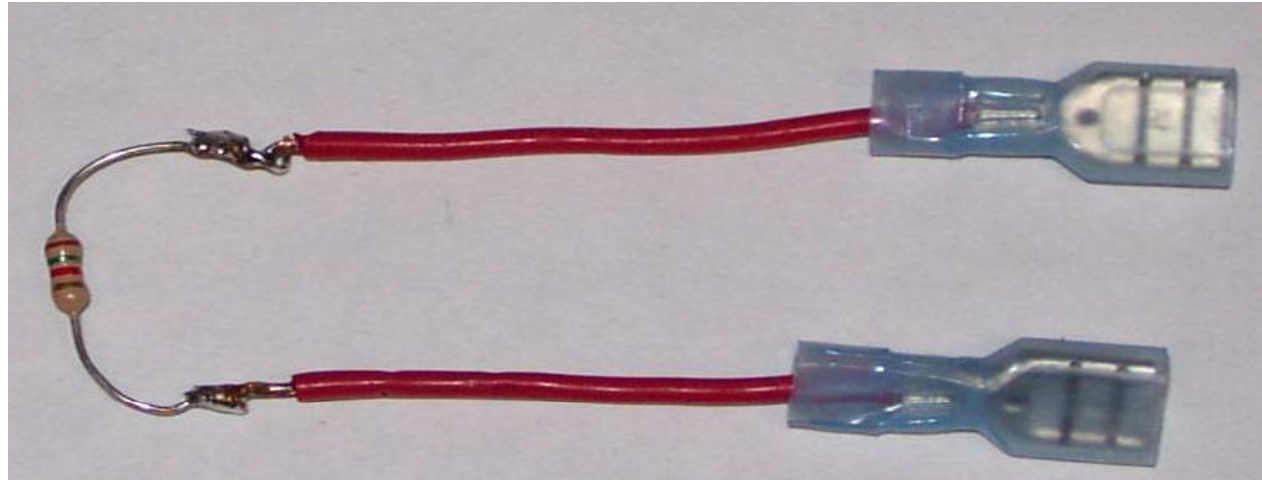

No resistor	2000 rpm
277 ohm resistor	2500 rpm
693 ohm resistor	3000 rpm
1500 ohm resistor	3500 rpm

This only applies to the new Danfoss BD35 and BD50 compressors

Plug in Multi Speed Board

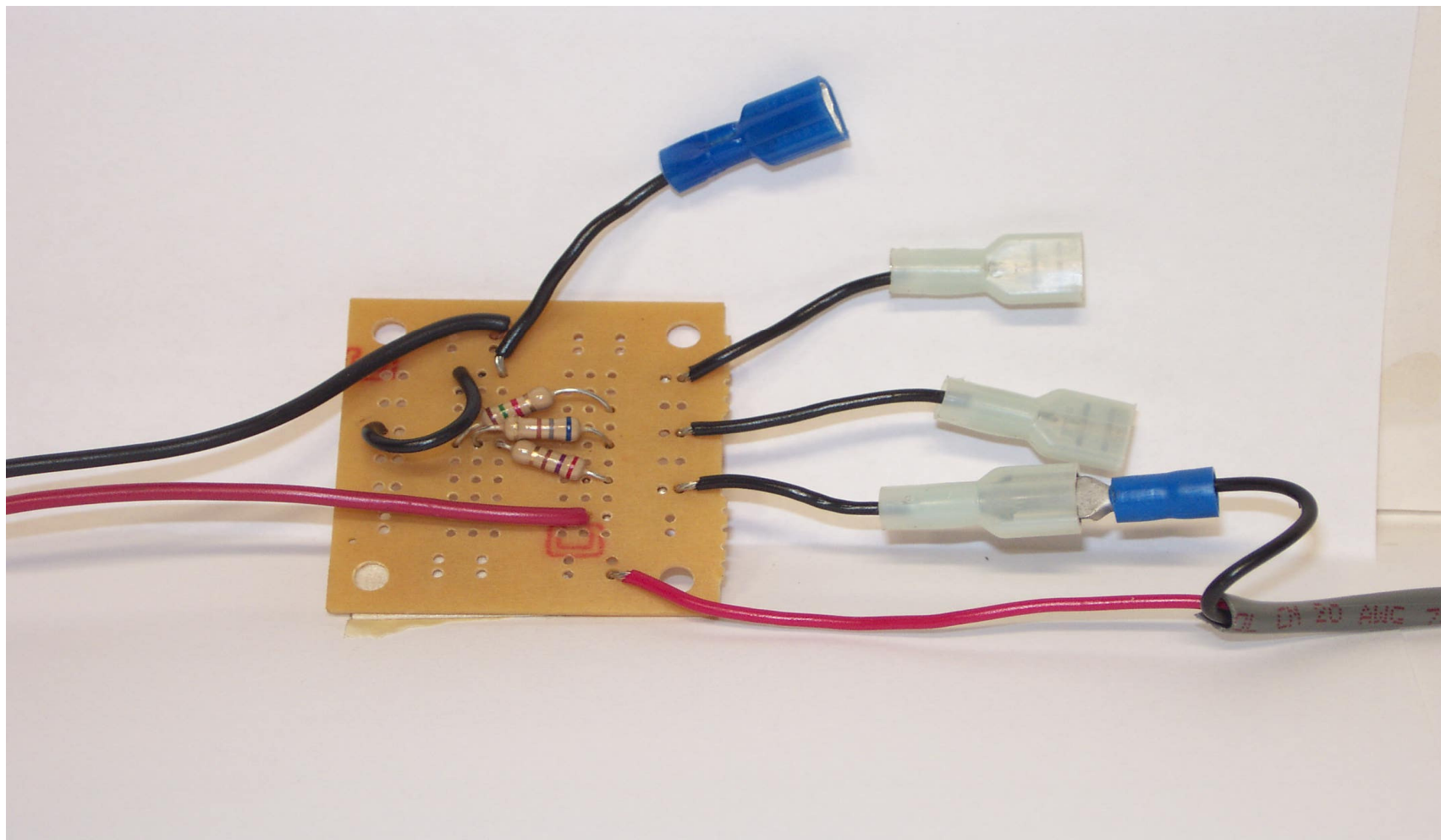

Automatic Speed Controls

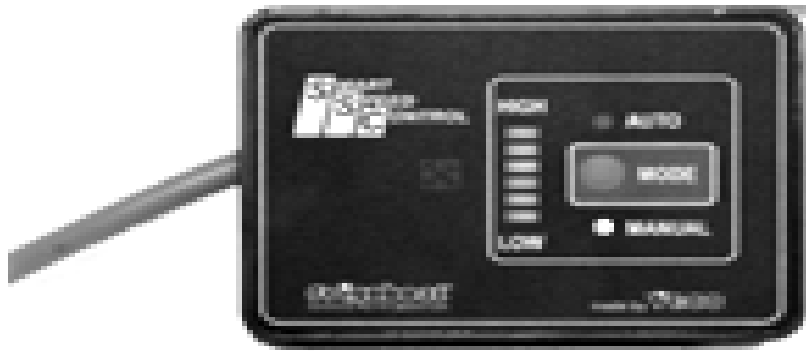

Frigoboat SSC Control

Works like an automatic transmission it selects speed based on cycling times. Light bar identifies speed. It can be operated in manual or automatic mode



Isotherm ASU Control

Makes small speed adjustments Based on box temperature. It offers an automatic speed up feature when a charging current is detected.

My book contains complete test data on both units

Troubleshooting

- **Your car has a computer readout for trouble faults, wouldn't it be great if the refrigerator unit had the same thing.**
- **The Danfoss BD35 and BD50 compressors do have a diagnostic circuit built into the electronic module but most manufacturers don't provide the LED or instructions on what the light flashes mean.**

My book contains troubleshooting techniques on all BD and Swing compressors

Troubleshooting New Danfoss Compressors

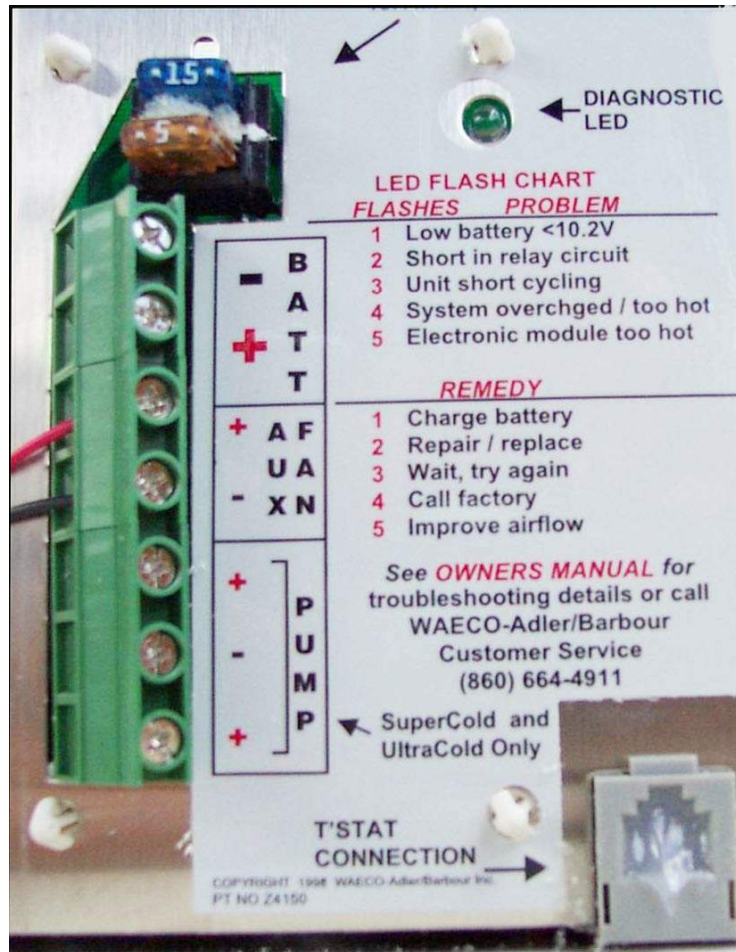

Adler Barbour Expansion Panel With LED



LED Connected to Module

Smart DC Power Generation

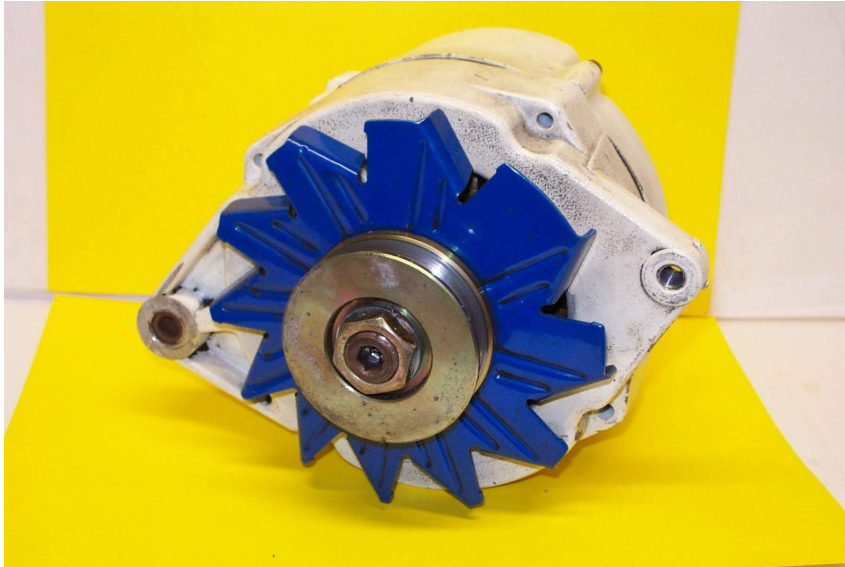

High Output Alternators

My tests show that a high output alternator With smart regulator can reduce engine run time by 700% over a standard alternator. This 70 Amp. Belmar produces 70 amps. during the beginning charge phase at 1000 Engine rpm.



Low Cost Smart Regulator

This model tested is basic but the results were good. The biggest problem with it is it does not have a start up time delay so it overloads the starting current on engine start.

DC Power Storage and Distribution

Battery Bank life is limited by:

- Design quality
- Operating and storage temperature
- Charge maintenance
- Age
- Total amp-hrs used.
Think of a deep cycle battery as having a consumable capacity. Each time it is discharged and recharged there is a loss in battery life.



Power Management Tools



Battery Combiner

An automatic switch that connects batteries together when a charging current is available and disconnects them when charging current is not present.



Battery Monitor

A battery monitor of some type is required to manage the onboard power distribution system. Gulf Carts use digital volt meters or battery energy meters. The best monitoring system for a Boat is one that records amp-hrs consumed and replaced like the E-Meter or a similar unit.

Basic Power Distribution

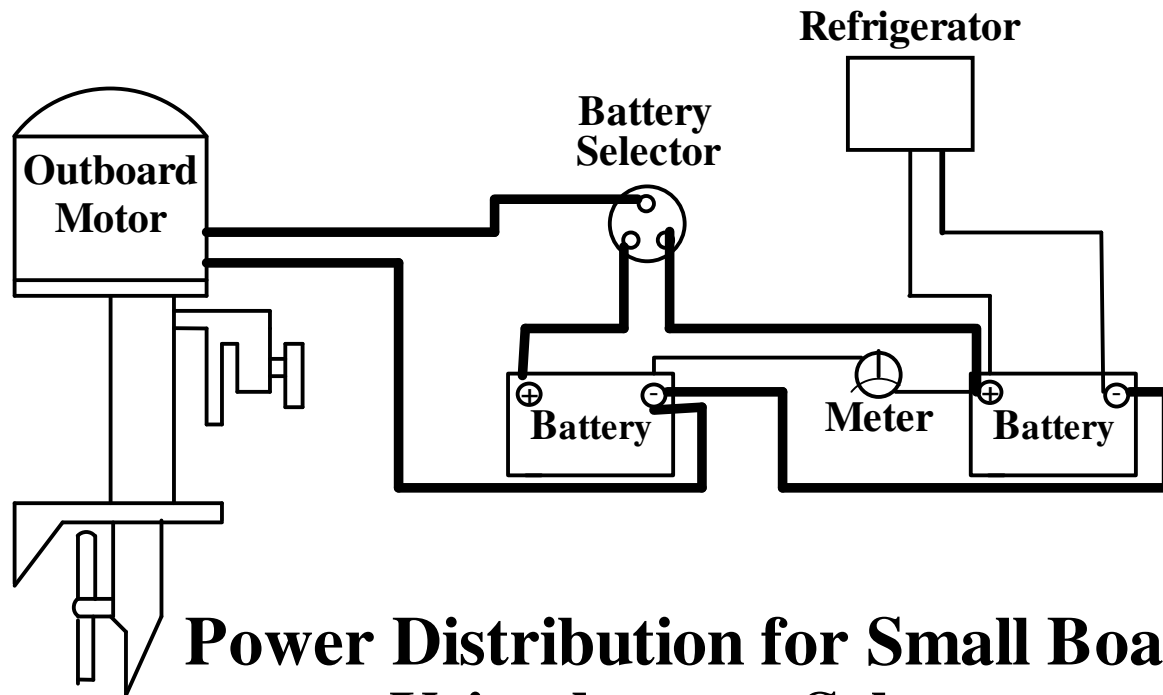

**Power Distribution for Small Boats
Using battery Selector**

Power For The Full Time Cruiser

Power Generation can be by:

- Engine Alternator
- Solar Panels
- Water Generator
- Battery Charger
- Or other source

Power Stored in three separate Battery Banks.

Batteries automatically charged by two Battery Combiners from Any generating source.

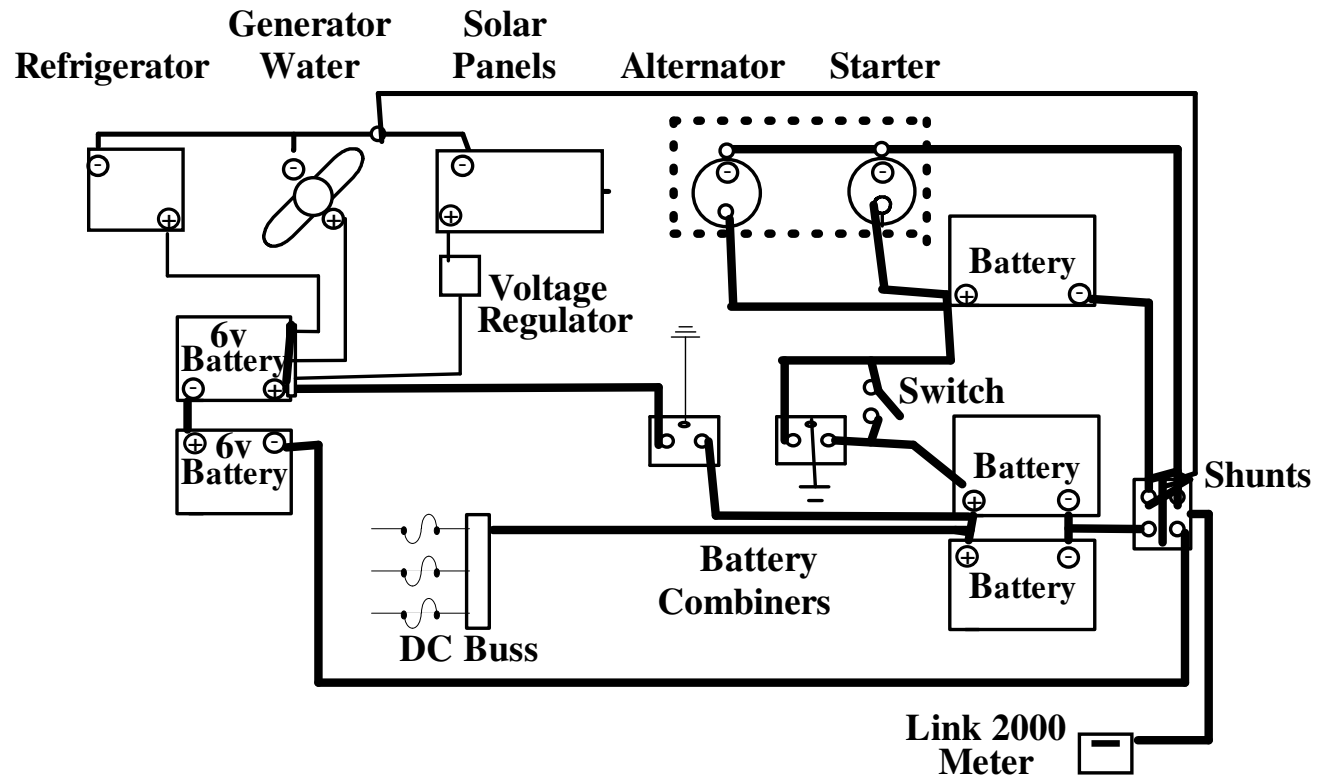

**Blue-water Boat DC Power
Distribution System**

MAKING ICE ON BOARD

Vertical Ice Tray



Bottle Ice Cubes

Standard Ice Tray



Automatic Ice Maker

**A cold drink as you sail into the sunset.
A perfect way to end a perfect day!**



For more technical information on boat refrigeration look through the various Pages of my web site at <http://www.kollmann-marine.com>